

flown with:
 C18-20-10 outrunner
 basic 10A ESC
 2s 350 mAh 40c LiPo
 6" x 5" prop

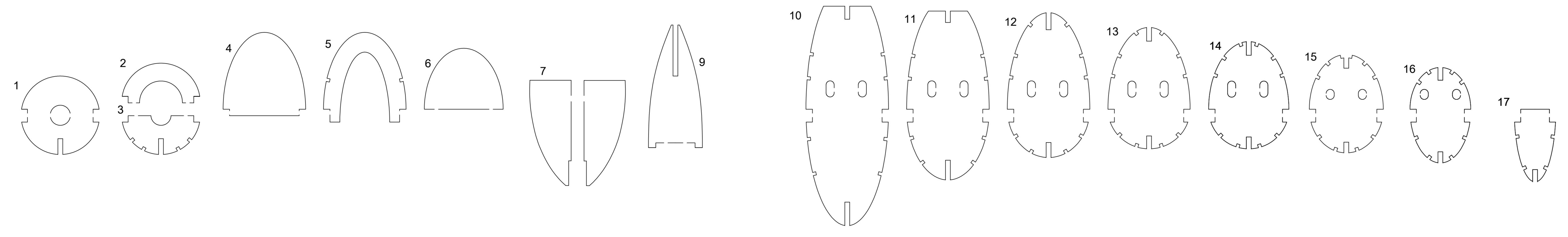

Scarab
 designed by Albert Hatfull for Worcraft circa 1949
 redraw in 2015 by Bryan Gostlow